

Clip in adjustable shelf runners

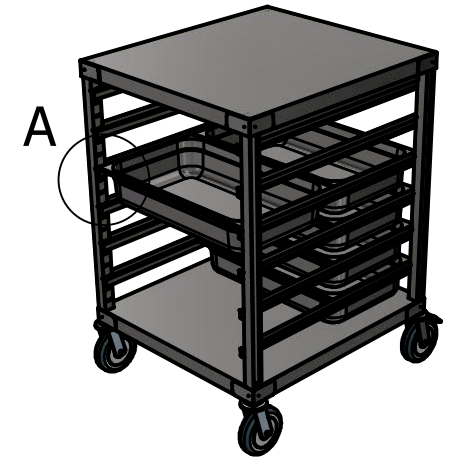

Moffat Specification

Dimensions
 length - 660mm
 Depth - 600mm
 Height - 900mm
 Weight - 18kg

Capacity
 6 x 2/1 100mm deep GN type pans
 or
 12 x 1/1 100mm deep GN type pans

Adjustable shelf height at 35mm increments

Materials
 1.2mm 304 Grade St/ Steel Top & Supports

Installation
 All swivel castors, two braked

ALL SHEET METAL DIMENSIONS ARE I/S (INSIDE SIZES) (UNLESS OTHERWISE STATED)

ALL DIMENSIONS IN (mm), TOLERANCE = LINEAR ± 0.5mm, ANGULAR ± 0.5mm (OR AS STATED). ALL SHARP EDGES TO BE REMOVED FROM SHEET METAL PARTS

Product	FABRICATION			Product No	 The Catering Equipment Company	
Description	AMRP					
Material/Finish	Thickness		Desp/Date		<small>No reproduction or publication of this drawing may be made, and no article may be manufactured or assembled in accordance with this drawing without prior written consent. This prohibition is a term of any contract relating to this drawing. Rights reserved under the Copyright Act 1956 as amended by the Design Copyright Act 1968.</small>	
Legacy P/N	Weight	18kg	Quote No.	Dwg No.		MRKA-074605
Client			SO Number	STD	Drawn By	N.Raymen
Client Project			Approved By		Date	16/06/2020
E & R MOFFAT LTD, SEABEGS ROAD, BONNYBRIDGE, FK4 2BS, T: +44 (0)1324 812272, E: sales@ermoffat.co.uk, Web: www.ermoffat.co.uk					Scale	1 : 20
					Sheet	1 / 1
						A4