

Right hand hinged door with soft closing hinges

Removable shelf adjustable in 55mm increments

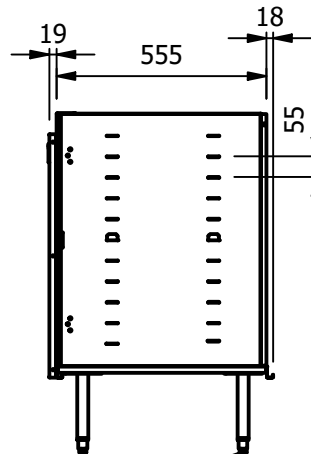

Adjustable for height legs

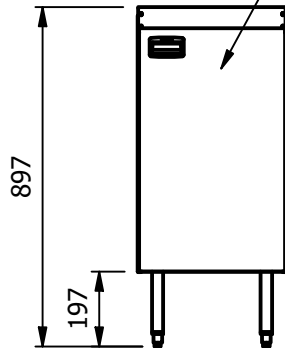
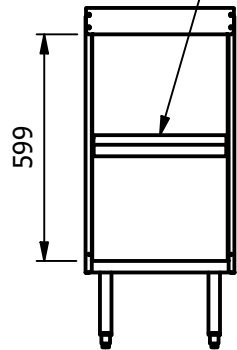
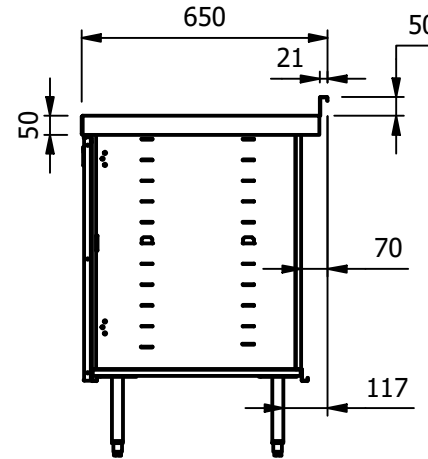

Moffat Specification

Floor standing drawer unit

Dimensions

Width - 390mm / 400mm with top
 Depth - 592mm / 650mm with top
 Height - 897mm / 900mm with Top
 Weight - 25kg

Capacity

115 liters

Materials

0.7mm 430 Grade St/ Steel Structure
 1.2mm 430 Grade St/ Steel Structure

Installation

Floor Standing with adjustable height legs

ALL SHEET METAL DIMENSIONS ARE I/S (INSIDE SIZES) (UNLESS OTHERWISE STATED)

ALL DIMENSIONS IN (mm), TOLERANCE = LINEAR ± 0.5mm, ANGULAR ± 0.5mm (OR AS STATED). ALL SHARP EDGES TO BE REMOVED FROM SHEET METAL PARTS

Product	FABRICATION			Product No							
Description	M1AR			<small>© No reproduction or publication of this drawing may be made, and no article may be manufactured or assembled in accordance with this drawing without prior written consent. This prohibition is a term of any contract relating to this drawing. Rights reserved under the Copyright Act 1956 as amended by the Design Copyright Act 1968.</small>							
Material/Finish	Thickness			Desp/Date							
Legacy P/N	Weight	25kg		Quote No.	Dwg No.	UMA-072441		Issue			
Client				SO Number	STD		Drawn By	ABB			
Client Project				Approved By			Date	05/05/2020			
E & R MOFFAT LTD, SEABEGS ROAD, BONNYBRIDGE, FK4 2BS, T: +44 (0)1324 812272, E: sales@ermoffat.co.uk, Web: www.ermoffat.co.uk							Scale	1 : 20	Sheet	1 / 2	A4

