

Six set of removable shelf runners adjustable in 55mm increments suitable for GN 1/1 type pans

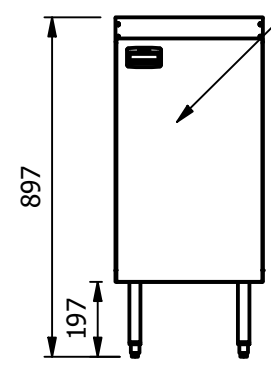

Right hand hinged door with soft closing hinges

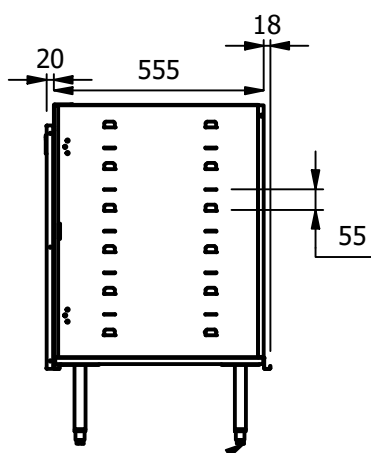

Adjustable for height legs

View with a standard work top with rear up-stand and 70mm rear void

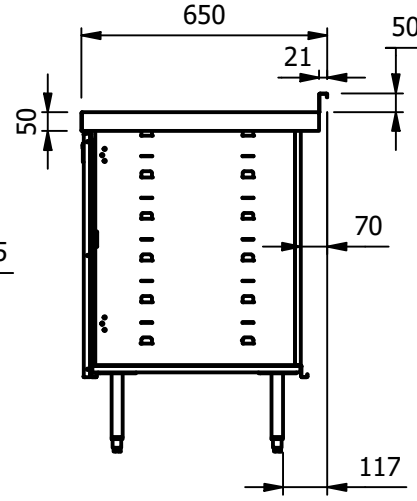

Moffat Specification

Floor standing unit designed to hold GN 1/1 type pans

Dimensions
 Width - 390mm / 400mm with top
 Depth - 592mm / 650mm with top
 Height - 897mm / 900mm with Top
 Weight - 25kg

Capacity
 115 liters
 5 off GN 1/1 pans 100mm deep or equivalent

Materials
 0.7mm 430 Grade St/ Steel Structure
 1.2mm 430 Grade St/ Steel Structure

Installation
 Floor Standing with adjustable height legs

ALL SHEET METAL DIMENSIONS ARE I/S (INSIDE SIZES) (UNLESS OTHERWISE STATED) ALL DIMENSIONS IN (mm), TOLERANCE = LINEAR ± 0.5mm, ANGULAR ± 0.5mm (OR AS STATED). ALL SHARP EDGES TO BE REMOVED FROM SHEET METAL PARTS

Product	FABRICATION			Product No	 The Catering Equipment Company				
Description	M1BR								
Material/Finish	Thickness		Desp/Date		<small>No reproduction or publication of this drawing may be made, and no article may be manufactured or assembled in accordance with this drawing without prior written consent. This prohibition is a term of any contract relating to this drawing. Rights reserved under the Copyright Act 1956 as amended by the Design Copyright Act 1968.</small>				
Legacy P/N	Weight	25kg	Quote No.						
Client			SO Number	STD	Dwg No.	UMA-072591	Issue		
Client Project			Approved By		Drawn By	ABB	-		
E & R MOFFAT LTD, SEABEGS ROAD, BONNYBRIDGE, FK4 2BS, T: +44 (0)1324 812272, E: sales@ermoffat.co.uk, Web: www.ermoffat.co.uk					Date	05/05/2020			
					Scale	1 : 20	Sheet	1 / 2	A4