

View with a standard sink top with rear up-stand and 70mm rear void

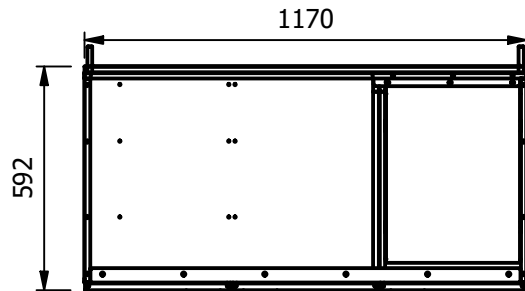

Hinged doors with soft closing hinges

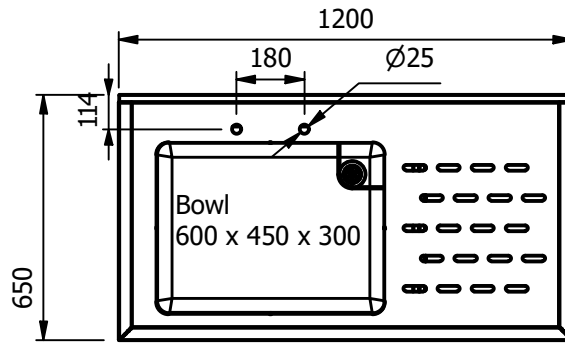
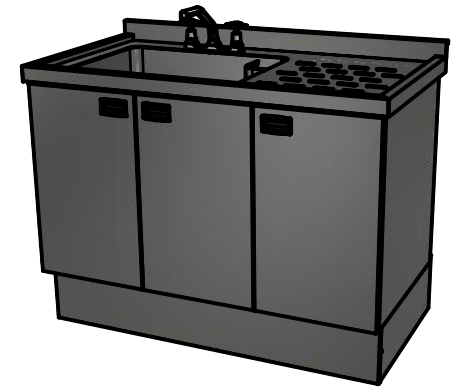

View with a typically sink top

Moffat Specification

Floor standing sink unit

Dimensions

Width - 1170mm / 1200mm with top
 Depth - 592mm / 650mm with top
 Height - 897mm / 900mm with Top
 Weight - 50kg

Sink

One piece with an anti drip edge all round.
 Bowl - 600mm x 450mm x 300mm [capacity 81 litres]
 Waste - 38mm with corner strainer and overflow tube.
 Tap holes - 2 x 25mm diameter at 180mm centers.
 Drainer - wipe dry with a relief patten.

Materials

0.7mm & 1.2mm 430 Grade St/ Steel Structure
 1.2mm 304 Grade St/ Steel Sink top

Installation

Floor Standing with adjustable height legs

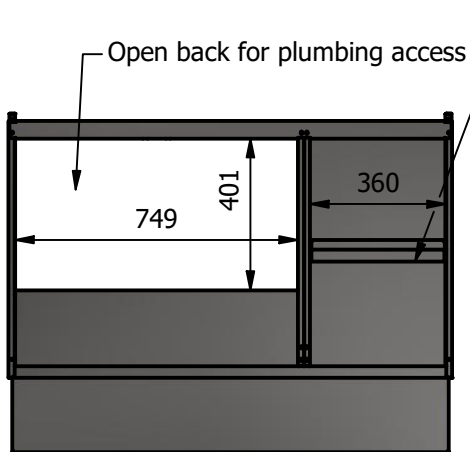

Open back for plumbing access

Removable shelf adjustable in 55mm increments

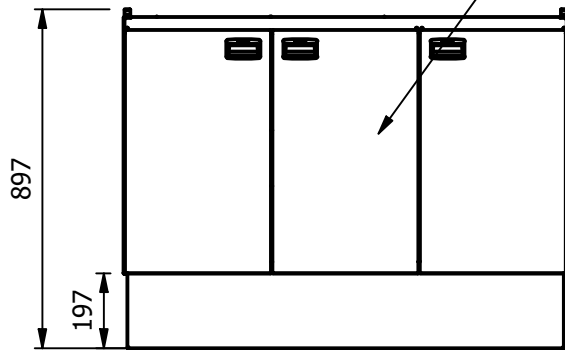

Adjustable for height legs

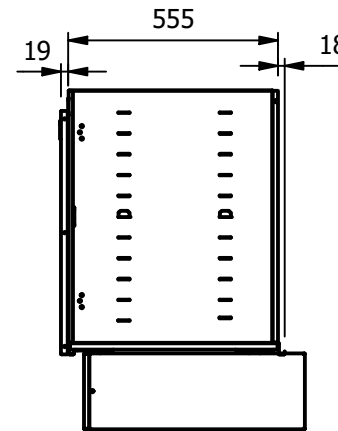

ALL SHEET METAL DIMENSIONS ARE I/S (INSIDE SIZES) (UNLESS OTHERWISE STATED)

ALL DIMENSIONS IN (mm), TOLERANCE = LINEAR ± 0.5mm, ANGULAR ± 0.5mm (OR AS STATED). ALL SHARP EDGES TO BE REMOVED FROM SHEET METAL PARTS

| | | | | | | | | | |
|---|-------------|------|-------------|------------|---|------------|-------|-------|-----------|
| Product | FABRICATION | | | Product No |  The Catering Equipment Company | | | | |
| Description | MSUL | | | | | | | | |
| Material/Finish | Thickness | | Desp/Date | | No reproduction or publication of this drawing may be made, and no article may be manufactured or assembled in accordance with this drawing without prior written consent. This prohibition is a term of any contract relating to this drawing. Rights reserved under the Copyright Act 1956 as amended by the Design Copyright Act 1968. | | | | |
| Legacy P/N | Weight | 50kg | Quote No. | | | | | | |
| Client | | | SO Number | STD | Dwg No. | UMA-072660 | Issue | | |
| Client Project | | | Approved By | | Drawn By | ABB | - | | |
| E & R MOFFAT LTD, SEABEGS ROAD, BONNYBRIDGE, FK4 2BS, T: +44 (0)1324 812272, E: sales@ermoffat.co.uk, Web: www.ermoffat.co.uk | | | | | Date | 07/05/2020 | | | |
| | | | | | Scale | 1 : 20 | Sheet | 1 / 2 | A4 |