

This unit is factory fitted with overhead cabinet adjustable type fixings, positioned on the inner top corners.

The wall bracket parts are supplied loose ready to fit to the wall.

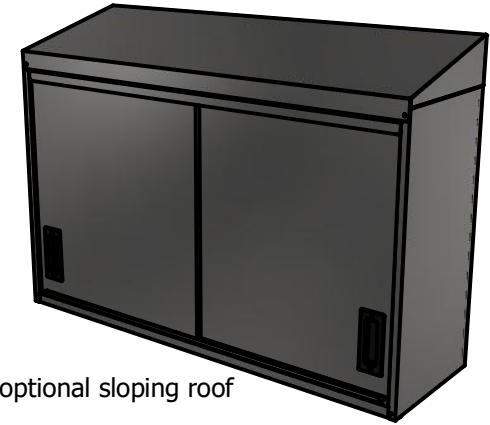

Shown with optional sloping roof

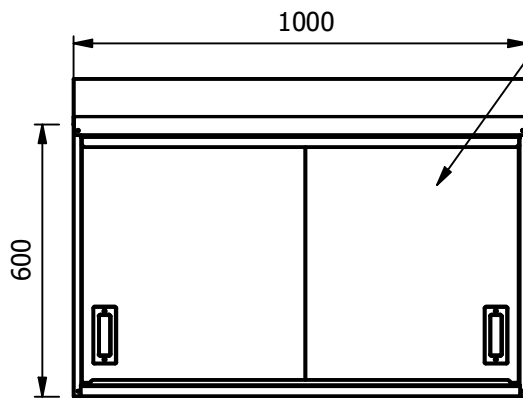
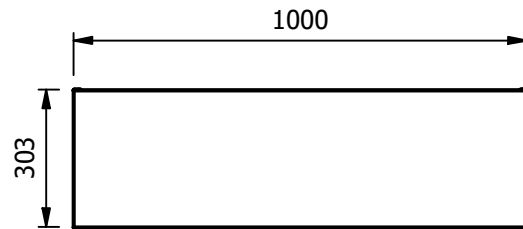

Sliding doors with double life skid pads

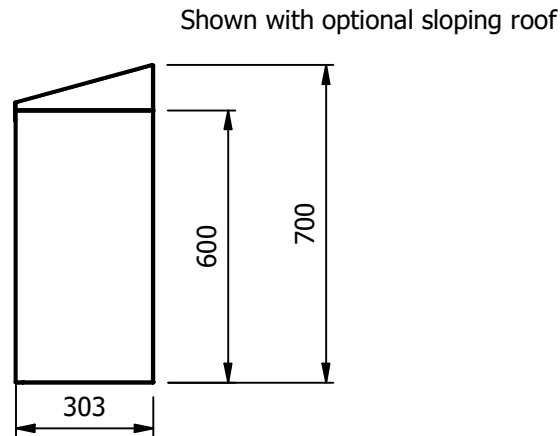

Shown with optional sloping roof

Moffat Specification

Wall mounted cupboard with sliding doors

Dimensions

Width - 1000mm

Depth - 303mm

Height - 600mm or 700mm with the sloping top option

Weight - 25kg

Capacity [usable inside space]

Width - 965mm

Depth - 250mm

Height - 570mm

Materials

0.7mm 430 Grade St/ Steel Structure

1.2mm 430 Grade St/ Steel Structure

Installation

Wall mounted with adjustable overhead cabinet brackets.

ALL SHEET METAL DIMENSIONS ARE I/S (INSIDE SIZES) (UNLESS OTHERWISE STATED)

ALL DIMENSIONS IN (mm), TOLERANCE = LINEAR ± 0.5mm, ANGULAR ± 0.5mm (OR AS STATED). ALL SHARP EDGES TO BE REMOVED FROM SHEET METAL PARTS

Product	FABRICATION			Product No							
Description	WC10S			<small>© No reproduction or publication of this drawing may be made, and no article may be manufactured or assembled in accordance with this drawing without prior written consent. This prohibition is a term of any contract relating to this drawing. Rights reserved under the Copyright Act 1956 as amended by the Design Copyright Act 1968.</small>							
Material/Finish	Thickness			Desp/Date							
Legacy P/N	Weight	25kg		Quote No.	N/A		Dwg No.	WCA-073122	Issue		
Client	N/A			SO Number	STANDARD		Drawn By	ABB			
Client Project	N/A			Approved By			Date	20/05/2020			
E & R MOFFAT LTD, SEABEGS ROAD, BONNYBRIDGE, FK4 2BS, T: +44 (0)1324 812272, E: sales@ermoffat.co.uk, Web: www.ermoffat.co.uk							Scale	.06	Sheet	1 / 2	A4

