

This unit is factory fitted with overhead cabinet adjustable type fixings, positioned on the inner top corners.

The wall bracket parts are supplied loose ready to fit to the wall.

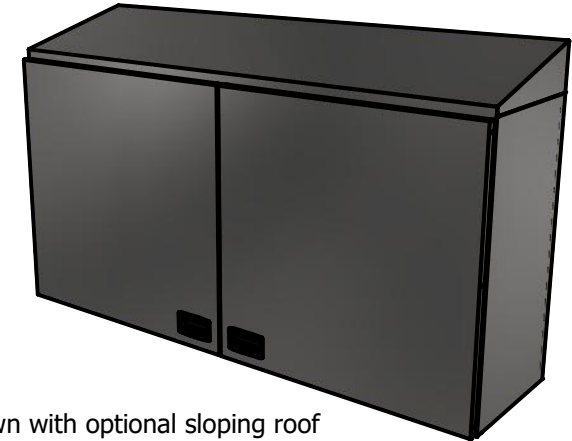

Shown with optional sloping roof

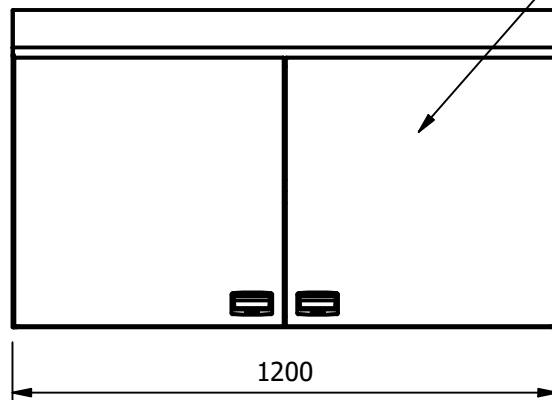
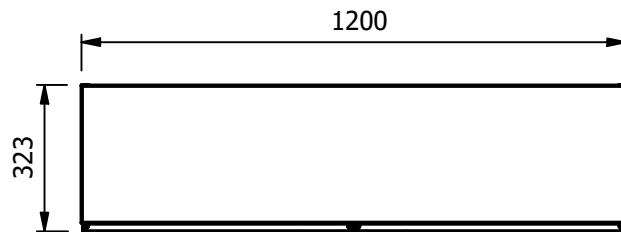

Soft closing hinged doors open 100°

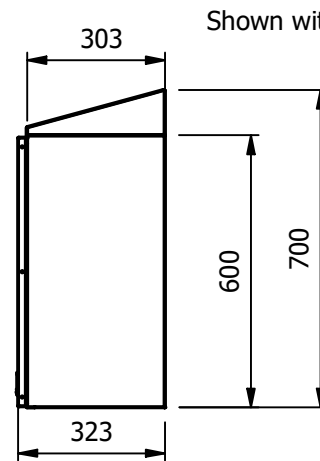

Shown with optional sloping roof

Moffat Specification

Wall mounted cupboard with hinged doors

Dimensions

Width - 1200mm
 Depth - 323mm/303mm
 Height - 600mm or 700mm with the sloping top option
 Weight - 29kg

Capacity [usable inside space]

Width - 1165mm
 Depth - 285mm
 Height - 570mm

Materials

0.7mm 430 Grade St/ Steel Structure
 1.2mm 430 Grade St/ Steel Structure

Installation

Wall mounted with adjustable overhead cabinet brackets.

ALL SHEET METAL DIMENSIONS ARE I/S (INSIDE SIZES) (UNLESS OTHERWISE STATED)

ALL DIMENSIONS IN (mm), TOLERANCE = LINEAR ± 0.5mm, ANGULAR ± 0.5mm (OR AS STATED). ALL SHARP EDGES TO BE REMOVED FROM SHEET METAL PARTS

Product	FABRICATION			Product No							
Description	WC12H										
Material/Finish	Thickness			Desp/Date							
Legacy P/N	Weight	29kg		Quote No.	N/A		Dwg No.	WCA-073789	Issue		
Client	N/A			SO Number	STANDARD		Drawn By	ABB			
Client Project	N/A			Approved By			Date	20/05/2020			
E & R MOFFAT LTD, SEABEGS ROAD, BONNYBRIDGE, FK4 2BS, T: +44 (0)1324 812272, E: sales@ermoffat.co.uk, Web: www.ermoffat.co.uk							Scale	.06	Sheet	1 / 2	A4

No reproduction or publication of this drawing may be made, and no article may be manufactured or assembled in accordance with this drawing without prior written consent. This prohibition is a term of any contract relating to this drawing. Rights reserved under the Copyright Act 1956 as amended by the Design Copyright Act 1968.

