

Four removable perforated shelving, adjustable for height in 100mm increments.

C ( 1 : 10 )

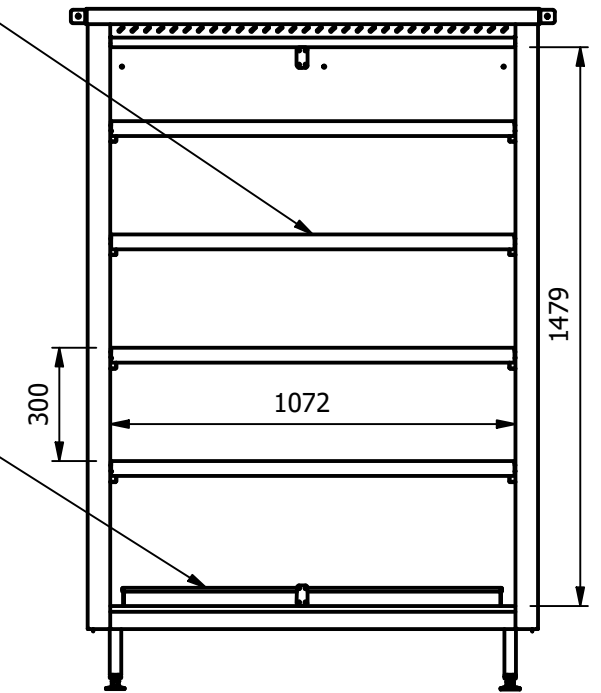
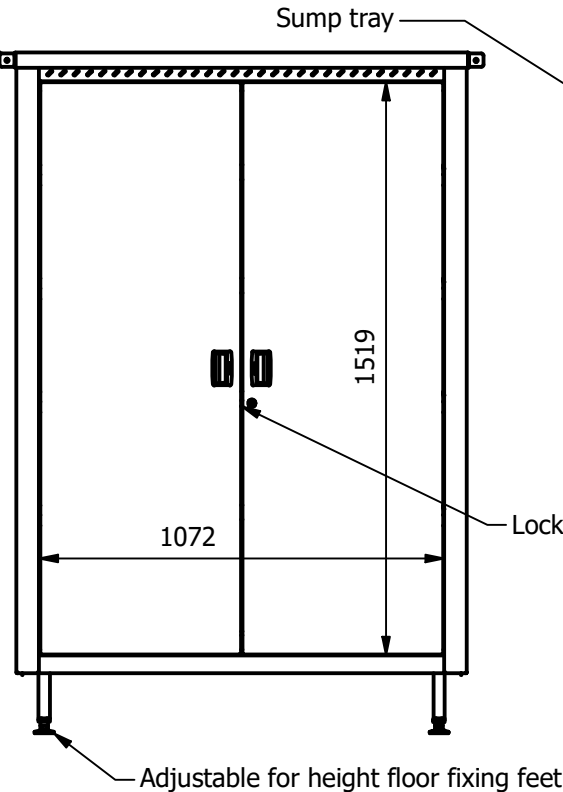
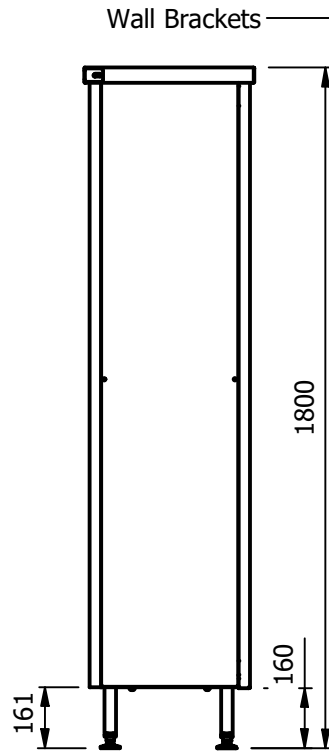
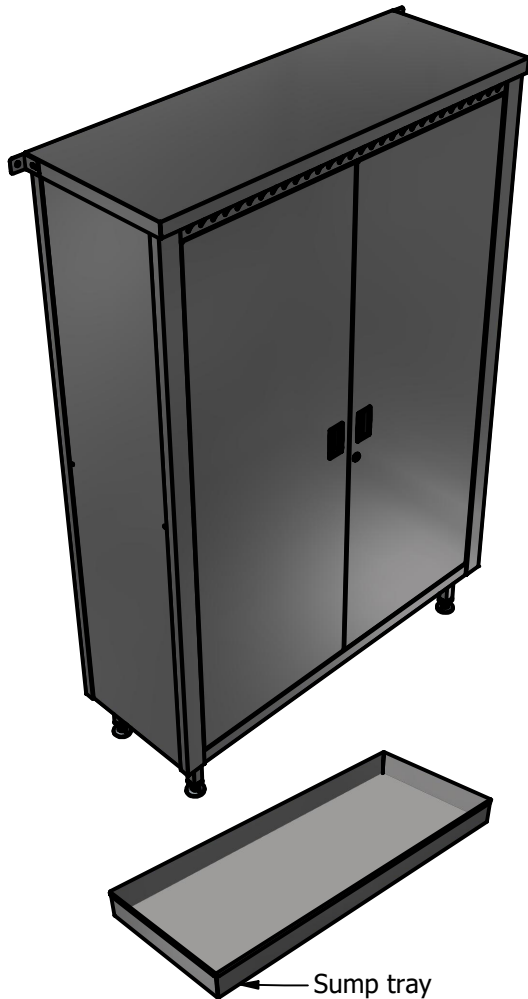
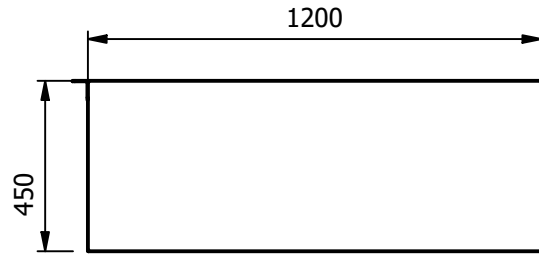

**Moffat Specification**

Storage cupboard with Base storage and four removable and adjustable, perforated stainless steel upper shelves.

Dimensions

Width - 1200mm  
Depth - 450mm  
Height - 1800mm  
Weight - 60kg

Capacity of Cupboard [usable inside space]

Width - 1072mm  
Depth - 358mm  
Usable Height -1479mm

Materials

1.2mm 304 Grade St/ Steel Top & Supports  
0.7mm 304 Grade St/ Steel Internal Structure

ALL SHEET METAL DIMENSIONS ARE I/S (INSIDE SIZES) (UNLESS OTHERWISE STATED)

ALL DIMENSIONS IN (mm), TOLERANCE = LINEAR ± 0.5mm, ANGULAR ± 0.5mm (OR AS STATED). ALL SHARP EDGES TO BE REMOVED FROM SHEET METAL PARTS

Product	COUNTERS			Product No							
Description	### CO124 ###										
Material/Finish	Thickness			Desp/Date							
Legacy P/N	Weight	60kg		Quote No.			Dwg No.	UMP-140591-1	Issue		
Client				SO Number	N/A		Drawn By	ABB			
Client Project				Approved By			Date	07/12/2022			
E & R MOFFAT LTD, SEABEGS ROAD, BONNYBRIDGE, FK4 2BS, T: +44 (0)1324 812272, E: sales@ermoffat.co.uk, Web: www.ermoffat.co.uk							Scale	1 : 20	Sheet	1 / 2	A4

No reproduction or publication of this drawing may be made, and no article may be manufactured or assembled in accordance with this drawing without prior written consent. This prohibition is a term of any contract relating to this drawing. Rights reserved under the Copyright Act 1956 as amended by the Design Copyright Act 1968.