

Four removable perforated shelving, adjustable for height in 100mm increments.

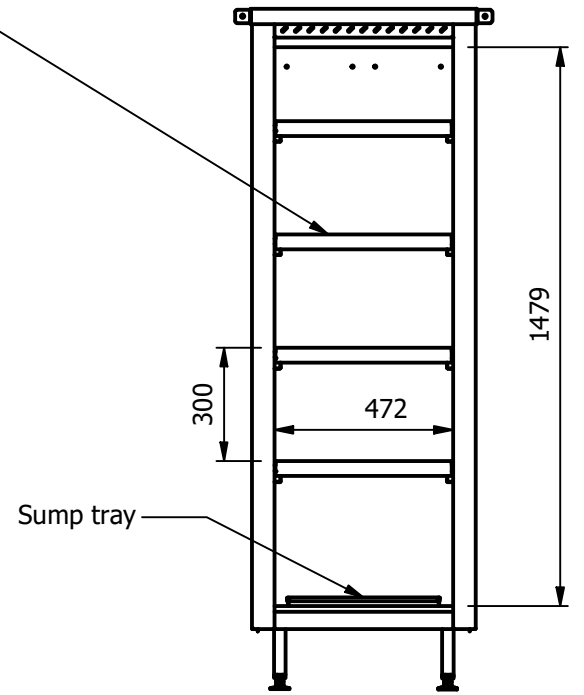
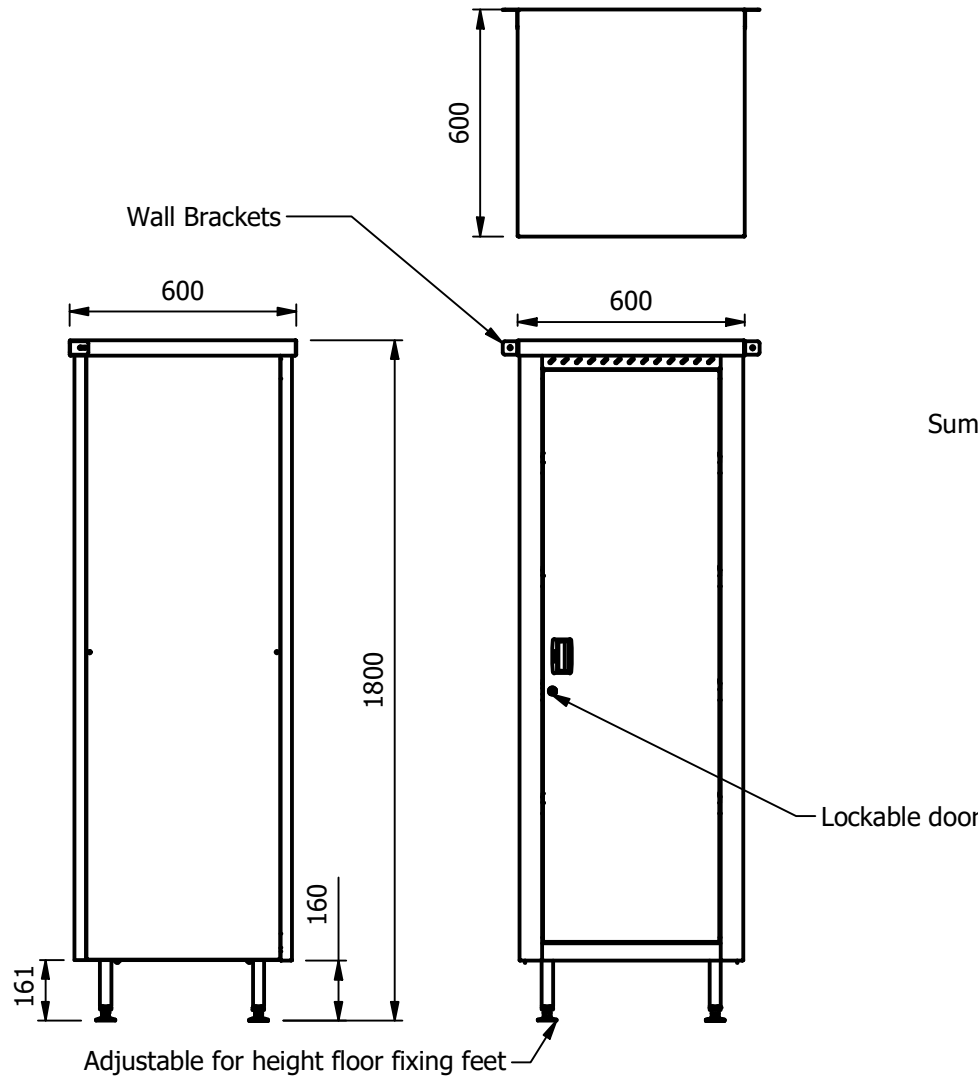

**Moffat Specification**  
 Storage cupboard with Base storage and four removable and adjustable, perforated stainless steel upper shelves.

Dimensions  
 Width - 600mm  
 Depth - 600mm  
 Height - 1800mm  
 Weight - 50kg

Capacity of Cupboard [usable inside space]  
 Width - 472mm  
 Depth - 508mm  
 Usable Height -1479mm

Materials  
 1.2mm 304 Grade St/ Steel Top & Supports  
 0.7mm 304 Grade St/ Steel Internal Structure

ALL SHEET METAL DIMENSIONS ARE I/S (INSIDE SIZES) (UNLESS OTHERWISE STATED) ALL DIMENSIONS IN (mm), TOLERANCE = LINEAR ± 0.5mm, ANGULAR ± 0.5mm (OR AS STATED). ALL SHARP EDGES TO BE REMOVED FROM SHEET METAL PARTS

|                 |              |      |  |             |     |  |   |
|-----------------|--------------|------|--|-------------|-----|--|---|
| Product         | COUNTERS     |      |  | Product No  |     |  |   |
| Description     | ### CO66 ### |      |  |             |     |  |   |
| Material/Finish | Thickness    |      |  | Desp/Date   |     |  |   |
| Legacy P/N      | Weight       | 50kg |  | Quote No.   |     |  |   |
| Client          |              |      |  | SO Number   | N/A |  |  |
| Client Project  |              |      |  | Approved By |     |  |   |

No reproduction or publication of this drawing may be made, and no article may be manufactured or assembled in accordance with this drawing without prior written consent. This prohibition is a term of any contract relating to this drawing. Rights reserved under the Copyright Act 1956 as amended by the Design Copyright Act 1968.

|          |              |       |       |
|----------|--------------|-------|-------|
| Dwg No.  | UMP-140332-1 | Issue |       |
| Drawn By | ABB          | -     |       |
| Date     | 07/12/2022   |       |       |
| Scale    | 1 : 20       | Sheet | 1 / 2 |