

Moffat Specification

Heated Display

Recirculated forced air system
LED Illumination
with internal adjustable shelving
ticket strips and front tray and
rear sliding double glazed doors

Capacity

0.14 m3

Dimensions

Width - 830mm
Depth - 660mm
Height - 816mm
Weight - 66kg

Power Rating

2.5kw
complete with a 2m long cord set & 13amp plug

Materials

1.2mm 304 Grade St/ Steel Top & Supports
0.7mm 430 Grade St/ Steel Internal Structure
6mm Tempered Glass

Installation

Counter Top Flush Fit Cut Out Dimensions
836mm x 666mm x 25mm
Counter Support Cut Out Dimensions
812mm x 642mm

Warning

Do not install unit in draughty conditions where the air movement is greater than 0.2mtr/sec.
e.g.near entrance/exit doors, open windows, under air conditioning units or a ceiling mounted fan
Ambient room conditions must not drop below 16°C .
Ticket strips must be in place on each shelf and the front tray must not be removed

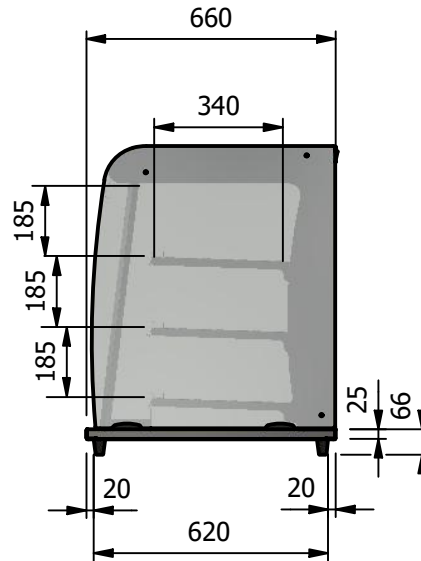
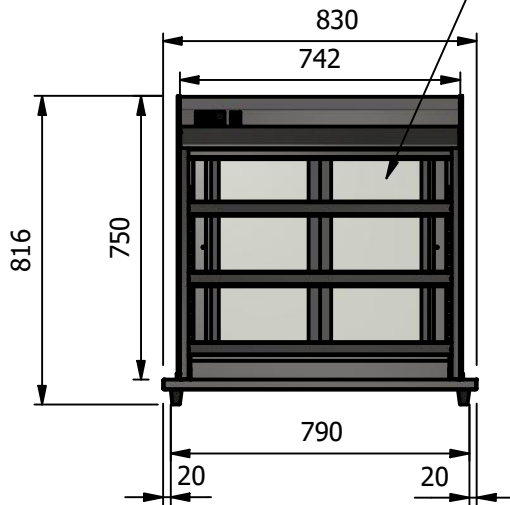

ALL SHEET METAL DIMENSIONS ARE I/S (INSIDE SIZES) (UNLESS OTHERWISE STATED)

ALL DIMENSIONS IN (mm), TOLERANCE = LINEAR ± 0.5mm, ANGULAR ± 0.5mm (OR AS STATED). ALL SHARP EDGES TO BE REMOVED FROM SHEET METAL PARTS

| | | | | | | | | | | | |
|---|-------------|------|--|-------------|-----|--|----------|------------|-------|-------|----|
| Product | GRAB & GO'S | | | Product No | | | | | | | |
| Description | D2GH | | | | | | | | | | |
| Material/Finish | Thickness | | | Desp/Date | | | | | | | |
| Legacy P/N | Weight | 66kg | | Quote No. | | | | | | | |
| Client | | | | SO Number | N/A | | Drawn By | ABB | | | |
| Client Project | | | | Approved By | | | Date | 26/02/2019 | | | |
| E & R MOFFAT LTD, SEABEGS ROAD, BONNYBRIDGE, FK4 2BS, T: +44 (0)1324 812272, E: sales@ermoffat.co.uk, Web: www.ermoffat.co.uk | | | | | | | Scale | 1:20 | Sheet | 1 / 2 | A4 |

No reproduction or publication of this drawing may be made, and no article may be manufactured or assembled in accordance with this drawing without prior written consent. This prohibition is a term of any contract relating to this drawing. Rights reserved under the Copyright Act 1956 as amended by the Design Copyright Act 1968.

