

DELIVERED FLAT
 No tools required for assembly
 Fold out legs fitted to top,
 separate undershelf clips into place.

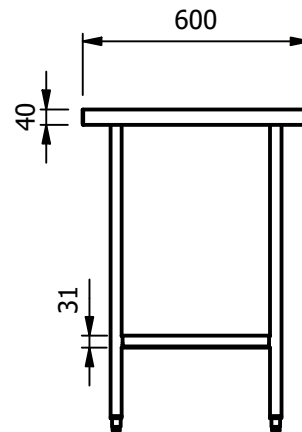
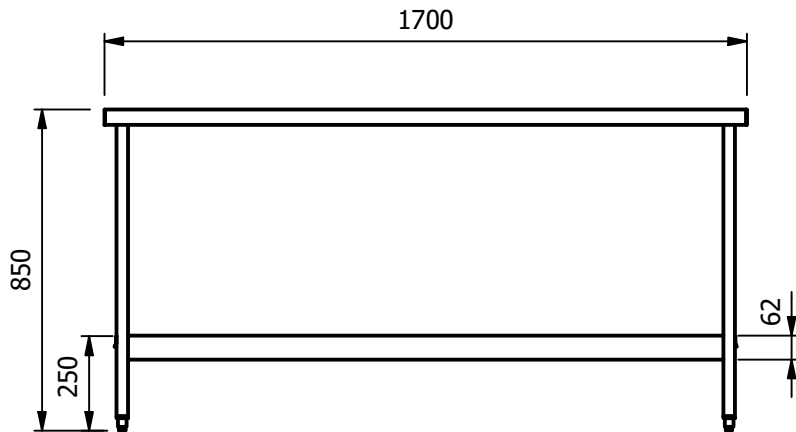

Moffat Specification

Dimensions

Width - 1700mm
 Depth - 600mm
 Height - 850mm
 Weight - 43kg

Materials

Top:- 1.2mm Thick 304 Grade St/Steel
 Top turndown (Front & Ends):- 40mm
 Upstand:- 40mm High / 6mm Return
 Undertop:- 1.2mm Thick Galvanised Steel
 Undershelf:- 1mm Thick 430 Grade St/Steel, 32mm Turndown
 Legs:- 30x30mm 430 Grade St/Steel
 Feet:- Aluminium Adjustable +20mm/-15mm
 c/w:- Earth Bonding Tab

ALL SHEET METAL DIMENSIONS ARE I/S (INSIDE SIZES) (UNLESS OTHERWISE STATED)

ALL DIMENSIONS IN (mm), TOLERANCE = LINEAR ± 0.5mm, ANGULAR ± 0.5mm (OR AS STATED). ALL SHARP EDGES TO BE REMOVED FROM SHEET METAL PARTS

Product	FABRICATION			Product No			
Description	F176CT						
Material/Finish	Thickness			Desp/Date			
Legacy P/N	Weight	41kg		Quote No.			
Client				SO Number	STANDARD		-
Client Project				Approved By			
E & R MOFFAT LTD, SEABEGS ROAD, BONNYBRIDGE, FK4 2BS, T: +44 (0)1324 812272, E: sales@ermoffat.co.uk, Web: www.ermoffat.co.uk				Scale	1 : 20	Sheet	1 / 1

No reproduction or publication of this drawing may be made, and no article may be manufactured or assembled in accordance with this drawing without prior written consent. This prohibition is a term of any contract relating to this drawing. Rights reserved under the Copyright Act 1956 as amended by the Design Copyright Act 1968.



Dwg No.	WBA-070994	Issue
Drawn By	N.Raymen	
Date	14/04/2020	