

Overview

The workhorse of the catering industry, the fetcher and carrier has so many uses from a food server to a clearing trolley. Uprights are made from 30mm square section stainless steel (type 304). Shelves manufactured from 1.2mm stainless steel (type 304) with radius internal corners and a 40mm raised lip and rolled edge all round to retain load.

Full width robust stainless steel push pull handles at both ends. All welded construction to form a heavy duty unit. Four revolving buffers fitted as standard. Complete with 125mm diameter. Swivel castors two with brakes. Option of two three or four shelves providing maximum storage. The robust compact mobile design provides sturdy and hygienic conveyance in a busy catering kitchen.

Note:

HTG models are designed to accommodate GN 1/1 gastronome pans.



Model HT3

Key Features:

- Uprights in 30mm square section stainless steel (type 304).
- Shelves manufactured from 1.2mm stainless steel (type 304) with radius bottom corners and 40mm raised lip fully around to retain load.
- Round stainless steel handle at both ends.
- All welded construction to form a heavy duty unit.
- 4 Revolving buffers fitted as standard.
- Complete with 125mm dia. Swivel castors 2 with brakes.



Shelving with internal radius bottom corners and drain holes

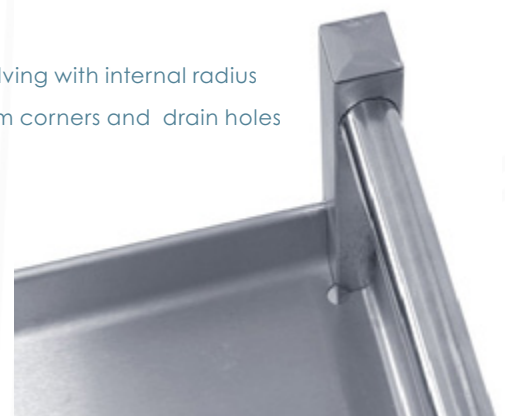



Model HT2

Model	Number of Shelves	Weight (kg)	L x W x H (mm)
HT2	2	20	876 x 626 x 950
HT3	3	25	876 x 626 x 950
HT4	4	30	876 x 626 x 1250
HTG2	2	26	1126 x 626 x 950
HTG3	3	33	1126 x 626 x 950
HTG4	4	39	1126 x 626 x 1250

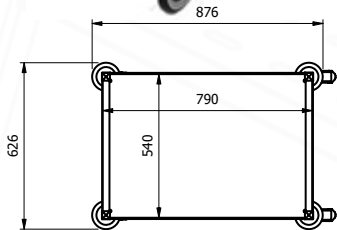

Model HT2

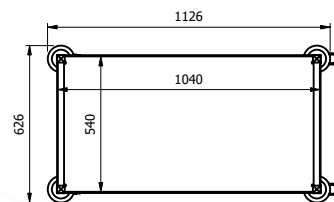

Model HTG2

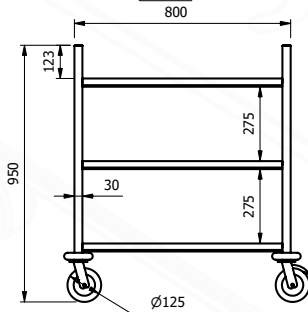
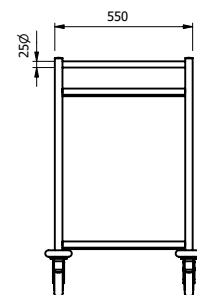
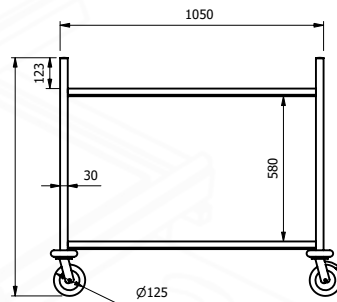
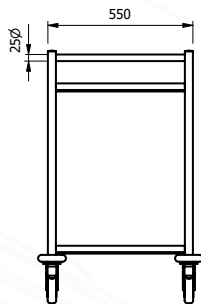
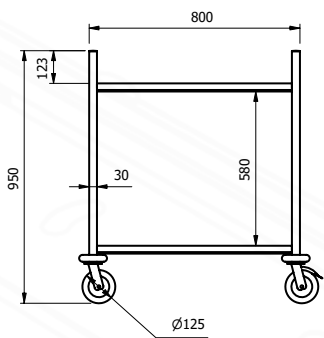

Model HT3

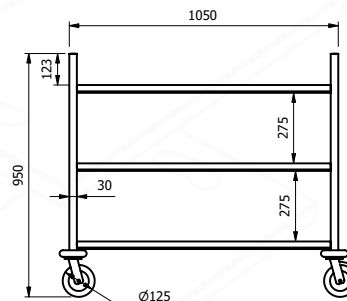

Model HTG3

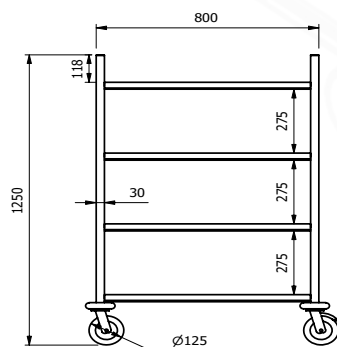

Model HT4

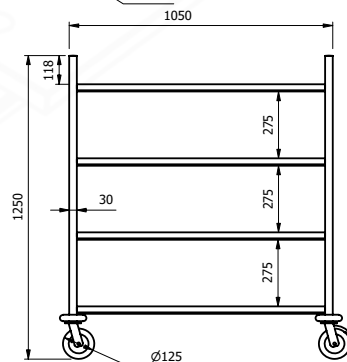

Model HTG4



E&R Moffat Ltd.
Bonnybridge
FK4 2BS
Scotland

Find us on:

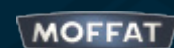

1963 - 2018

www.ermoffat.co.uk
+44 (0) 1324 812272
sales@ermoffat.co.uk