

Overview

Model P1G – 3 Zone Oven, with a Neo-Ceram Hot Top and Gantry.

Cook & Serve

Purpose-built for cooking, regenerating, and serving fresh, chilled, or frozen bulk food, this unit gives customers the flexibility to choose their meal at the point of service. It's ideal for multi-food portioning and distribution, featuring two completely independent ovens with unique multi-fan air re-circulation system allowing fast and even heat distribution throughout. Optimized for GN (Gastronorm) containers, there are eight shelf position in the oven set at 71 mm intervals . This allows up to eight GN 1/1 containers. Moffat's pioneering three-zone, multi-heat control system, provides precise management of food temperature, texture, and presentation. It also uses a unique multi-fan air recirculation system to deliver rapid, even heat distribution throughout. A stylish, black ceramic illuminated hot-top offers a self-regulating surface ideal for serving hot meals. Built for durability and hygiene, the unit features a bright polished stainless steel interior, satin-finished exterior panels, and plastic-coated front and sides. Heavy-duty hinged doors with robust slam-shut catches ensure long-lasting performance in demanding environments.



Features:

- LED display lighting and coloured LED oven mode indication (flash red when oven door is left open)
- Food probe and HACCP data gathering system.
- 1/1 GN compatible. Simple to transfer to serving area or load from a companion trolley.
- Neo-Ceram, thermo-panel hot top. (Self regulates around 95°C)
- Steam automatic evac system & oven door air curtain.
- Touch screen, total control system with multi function display and program choice.
- 3 fully controllable oven zones in a landscape configuration.
- Multi fans deliver even heating across the entire oven chamber, ensuring consistent cooking results.
- Designed for bulk production, with 8 shelf capacity in the oven (shelf pitch is 71mm)
- Wide choice of coloured front & end panels. (Standard colour is Goose Wing Grey)
- 4 x precision castors, 2 swivel with brakes and 2 fixed. (Easy to push in a straight line)
- Shelving and supports are removable for easy cleaning.
- Hi-Tech insulation.
- Cool to touch door with fully adjustable heavy duty hinges and a slam catch maintaining a tight seal.



Oven Mode Indication

Accessories:

- Fold-down end shelves, up to four can be fitted, two on each side.
- Fold down waste bag holder. This can be fitted on the left or right hand side.
- Fold-down front tray-slide with 3 apertures for cutlery holders.
- Cutlery holders cups for front tray slide option.
- Additional grid shelves. Note: 8 shelves are supplied for the oven.
- Tow bar & hitch attachment.
- Gastronorm containers.
- Cassette and transfer dolly system in place of the standard shelf hangers.



“Master every meal with a 3-zone oven that cooks high, medium, and low density foods simultaneously.”



Models	Weight (kg)	Length x Width x Height (mm)	Electrical Supply	Power Rating (kw)
P1G13	109	820 x 740 x 1372	1 x 13amp 1 PH	2.5
P1G16	109	820 x 740 x 1372	1 x 16amp 1 PH	2.5
P1G163	109	820 x 740 x 1372	1 x 16amp 3PH	3.75
P1G323	109	820 x 740 x 1372	1 x 32amp 3 PH	3.75

Operating modes:

Cook & Serve - Use in the same manner as a traditional convection oven

Cook Chilled - Regeneration of chilled bulk food [0°C to 8°C optimum 5°C] to above 82°C

Cook Frozen - Regeneration of frozen bulk food [-6°C to -25°C optimum -18°C] to above 82°C

Keep Hot - Holding hot bulk food above 63°C, compartment controlled at 90°C

Serve Hot - Hot-top serving area controlled at 90°



	Oven Capacity (Usable space totals 113 litres)	Glass Top Area (Heated area)
Width	540 mm	700mm
Depth	350 mm	550 mm
Pitch (per shelf)	71 mm	N/A
8 Grid Shelf Positions (8 Supplied)		

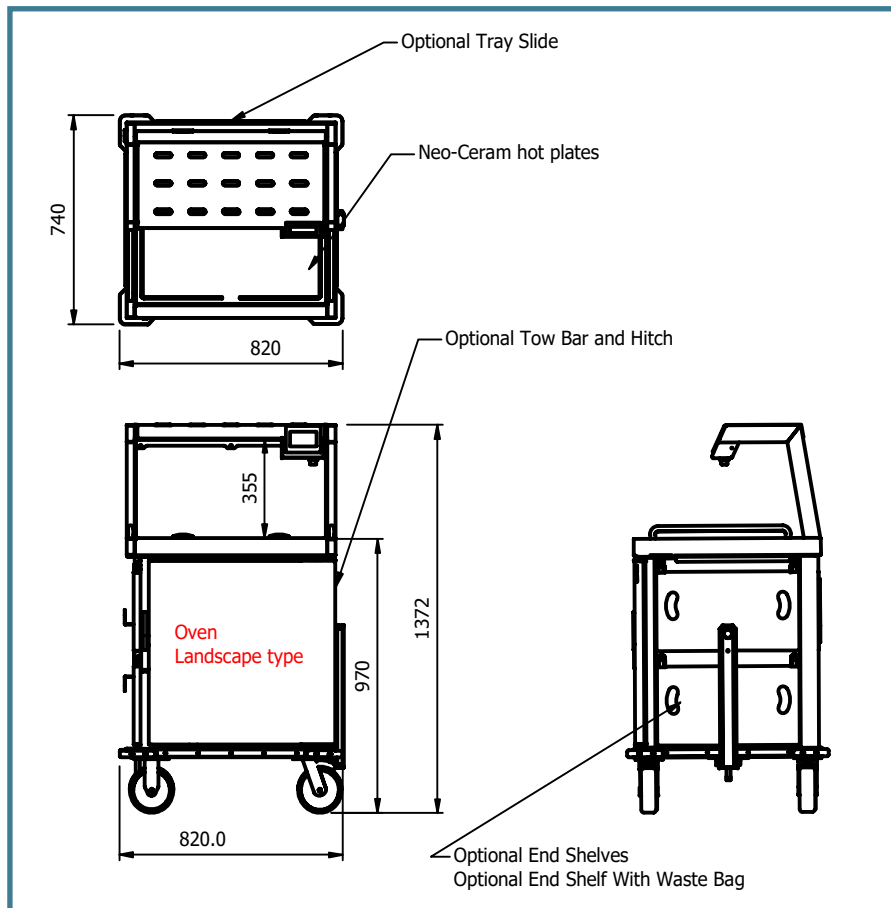

MADE IN BRITAIN

E&R Moffat Ltd.
Bonnybridge
FK4 2BS
Scotland



www.ermoffat.co.uk
+44 (0) 1324 812272
sales@ermoffat.co.uk