

A (1 : 8)

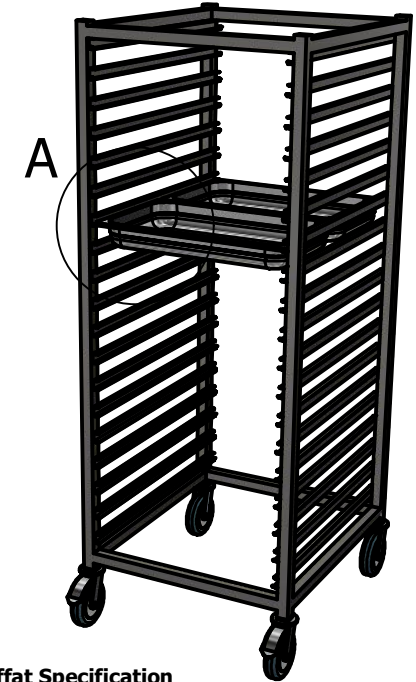
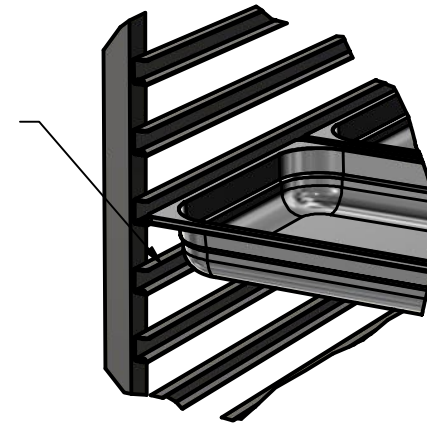

Moffat Specification

Dimensions
 length - 672mm
 Depth - 600mm
 Height - 1600mm
 Weight - 26kg

Capacity
 18 x 2/1 65mm deep Gastronorm type pans
 or
 36 x 1/1 65mm deep Gastronorm type pans

Shelf pitch 72mm

Materials
 1.2mm 304 Grade St/ Steel 30 x 30 tube frame

Installation
 All swivel castors, two braked

ALL SHEET METAL DIMENSIONS ARE I/S (INSIDE SIZES) (UNLESS OTHERWISE STATED)

ALL DIMENSIONS IN (mm), TOLERANCE = LINEAR ± 0.5mm, ANGULAR ± 0.5mm (OR AS STATED). ALL SHARP EDGES TO BE REMOVED FROM SHEET METAL PARTS

Product	FABRICATION			Product No	<small>© No reproduction or publication of this drawing may be made, and no article may be manufactured or assembled in accordance with this drawing without prior written consent. This prohibition is a term of any contract relating to this drawing. Rights reserved under the Copyright Act 1956 as amended by the Design Copyright Act 1968.</small>	 The Catering Equipment Company	
Description	SMG						
Material/Finish	30mm SQ 430 TUBE	Thickness		Desp/Date	Dwg No.	MRKA-074632	
Legacy P/N		Weight	26kg	Quote No.			
Client				SO Number	STD	Drawn By	N.Raymen
Client Project				Approved By		Date	17/06/2020
E & R MOFFAT LTD, SEABEGS ROAD, BONNYBRIDGE, FK4 2BS, T: +44 (0)1324 812272, E: sales@ermoffat.co.uk, Web: www.ermoffat.co.uk						Scale	1 : 20
						Sheet	1 / 1
							A4